

Artificial Intelligence

3. Constraint Satisfaction Problems

Lars Schmidt-Thieme

Information Systems and Machine Learning Lab (ISMLL)
Institute of Economics and Information Systems
& Institute of Computer Science
University of Hildesheim
<http://www.ismll.uni-hildesheim.de>

1. Constraint Satisfaction Problems

2. Backtracking Search

3. Local Search

4. The Structure of Problems

Problem Definition

A **constraint satisfaction problem** consists of

variables X_1, X_2, \dots, X_n with **values** from given domains $\text{dom } X_i$
($i = 1, \dots, n$).

constraints C_1, C_2, \dots, C_m i.e., functions defined on some
variables $\text{var } C_j \subseteq \{X_1, \dots, X_n\}$:

$$C_j : \prod_{X \in \text{var } C_j} \text{dom } X \rightarrow \{\text{true}, \text{false}\}, \quad j = 1, \dots, m$$

Assignments

assignment: assignment A of values to some variables

$\text{var } A \subseteq \{X_1, \dots, X_n\}$, i.e.,

$$A : X_3 = 7, X_5 = 1, X_6 = 2$$

An assignment A that does not violate any constraint is called **consistent / legal:**

$$C_j(A) = \text{true} \quad \text{for } C_j \text{ with } \text{var } C_j \subseteq \text{var } A, j = 1, \dots, m$$

An assignment A for all variables is called **complete:**

$$\text{var } A = \{X_1, \dots, X_n\}$$

A consistent complete assignment is called **solution.**

Some CSPs additionally require an objective function to be maximal.

Example / 8-Queens

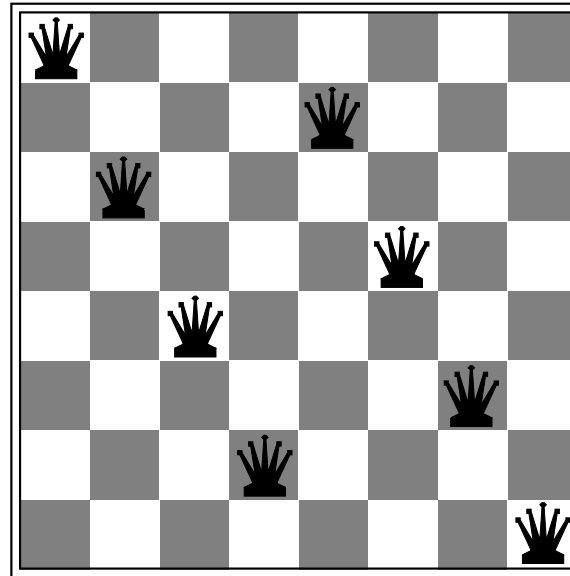

variables: $Q_1, Q_2, Q_3, Q_4, Q_5, Q_6, Q_7, Q_8$

domains: $\{1, 2, 3, 4, 5, 6, 7, 8\}$.

constraints: $Q_1 \neq Q_2, Q_1 \neq Q_2 - 1, Q_1 \neq Q_2 + 1,$
 $Q_1 \neq Q_3, Q_1 \neq Q_3 + 2, Q_1 \neq Q_3 - 2, \dots$

consistent assignment:

$Q_1 = 1, Q_2 = 3, Q_3 = 5, Q_4 = 7, Q_5 = 2, Q_6 = 4, Q_7 = 6$

Example / Map Coloring

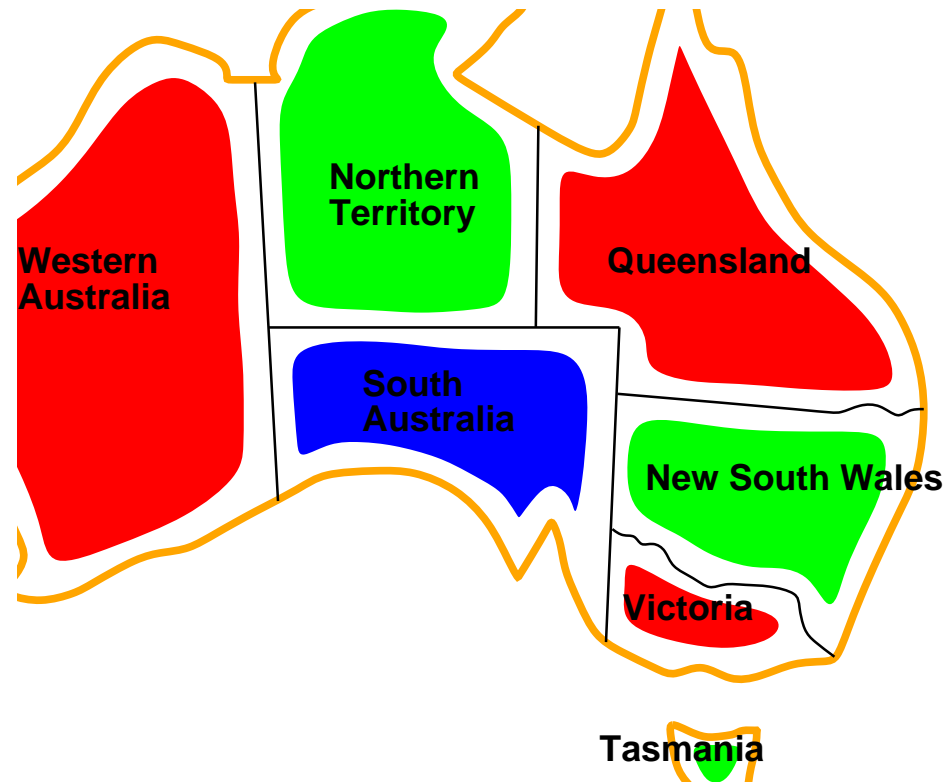

variables: WA, NT, SA, Q, NSW, V, T

domains: { red, green, blue }

constraints: $WA \neq NT$, $WA \neq SA$, $NT \neq SA$, $NT \neq Q$, ...

solution:

$WA = \text{red}$, $NT = \text{green}$, $SA = \text{blue}$, $Q = \text{red}$, $NSW = \text{green}$, $V = \text{red}$, $T = \text{green}$

CSP as Search Problems

Incremental formulation:

states:

consistent assignments.

initial state:

empty assignment.

successor function:

assign any not yet assigned variable
s.t. the resulting assignment still is consistent.

goal test:

assignment is complete.

path cost:

constant cost 1 for each step.

Types of Variables & Constraints

	finite domains	infinite domains
condition:	$ \text{dom } X_i \in \mathbb{N} \quad \forall i$	otherwise
example:	8-queens: $ \text{dom } Q_i = 8$. map coloring: $ \text{dom } X_i = 3$.	scheduling: $\text{dom } X_i = \mathbb{N}$ (number of days from now)
special cases:	binary CSPs: $ \text{dom } X_i = 2$	integer domains: $\text{dom } X_i = \mathbb{N}$ continuous domains: $\text{dom } X_i = \mathbb{R}$ (or an interval)
constraints	can be provided by enumeration, e.g., $(WA, NT) \in$ $\{(r, g), (r, b), (g, r), (g, b), (b, r), (b, g)\}$	must be specified using a constraint language , e.g., linear constraints.

Binary Constraints

Constraints can be classified by the number $|\text{var } C_j|$ of variables they depend on:

unary constraint: depends on a single variable X_i .

uninteresting: can be eliminated by inclusion in the domain $\text{dom } X_i$.

binary constraint: depends on two variables X_i and X_j .

can be represented as a constraint graph.



original map

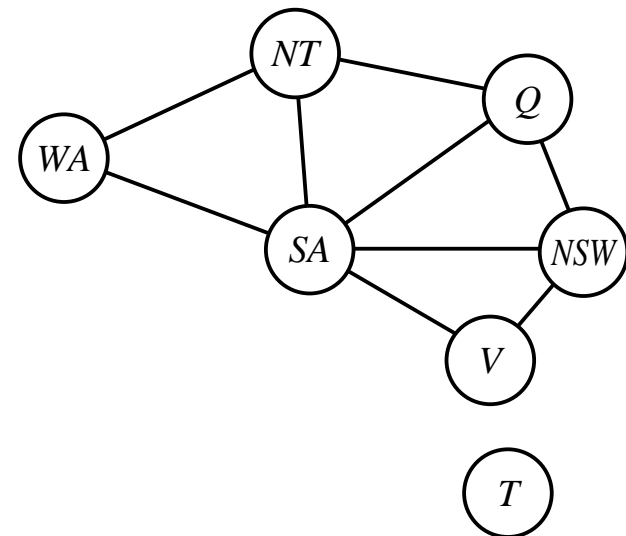

constraint graph

n -ary Constraints

constraint of higher order / n -ary constraint: depends on more than two variables.
can be represented as a constraint hypergraph.

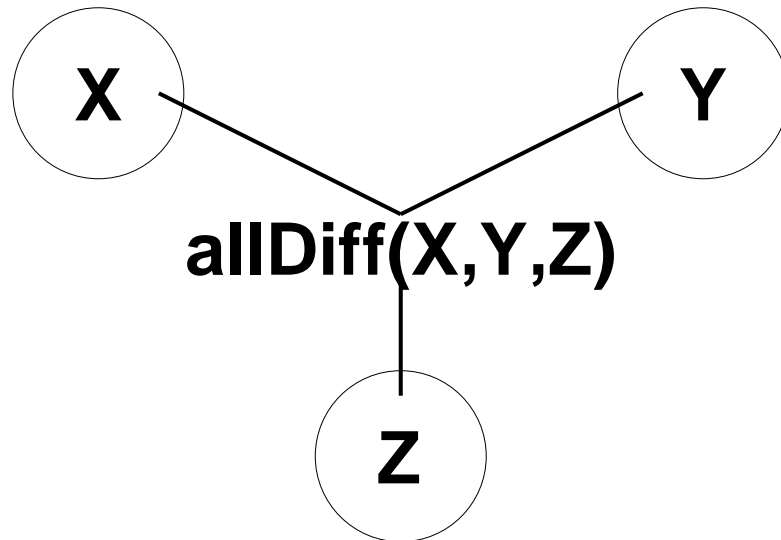

constraint hypergraph

n -ary Constraints

n -ary constraints sometimes can be reduced to binary constraints in a trivial way.

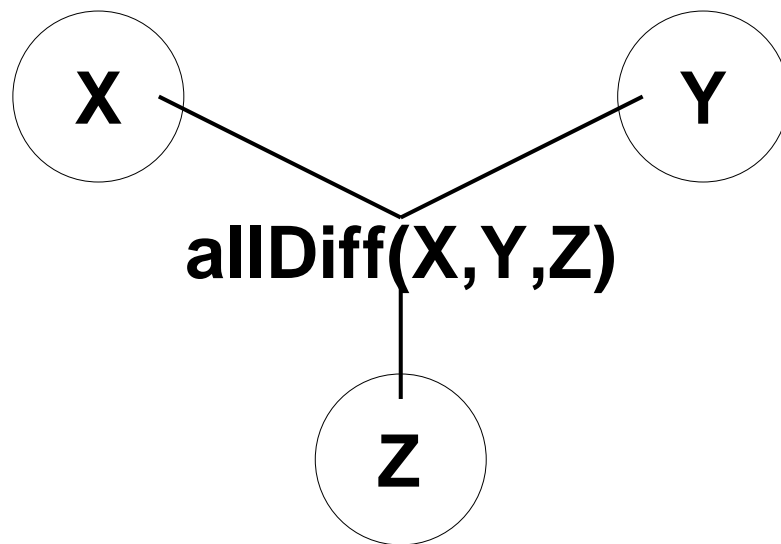

constraint hypergraph

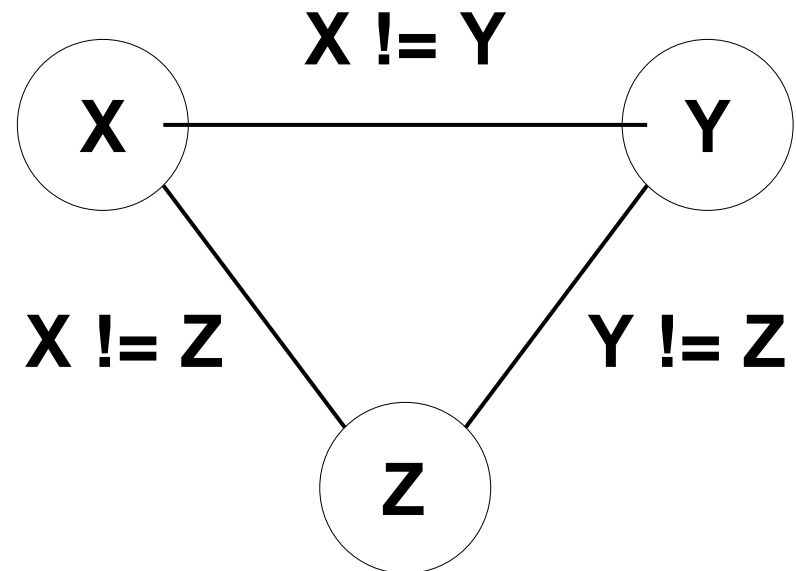

binarized constraint graph

n -ary Constraints

n -ary constraints always can be reduced to binary constraints by introducing additional **auxiliary variables** with the cartesian product of the original domains as new domain and the original n -ary constraint as unary constraint on the auxiliary variable.

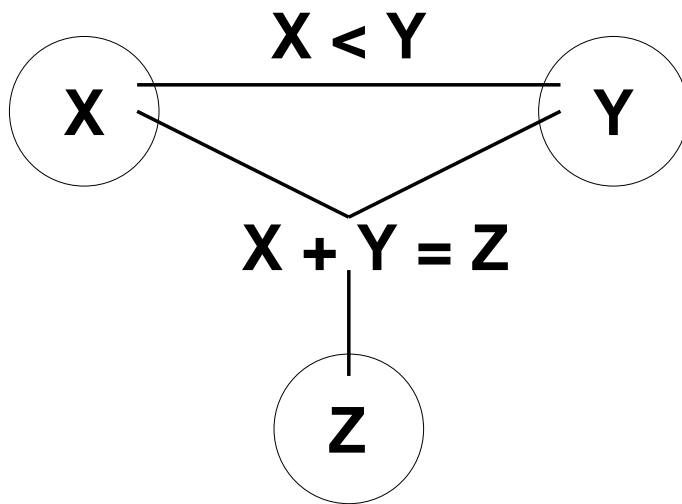

constraint hypergraph

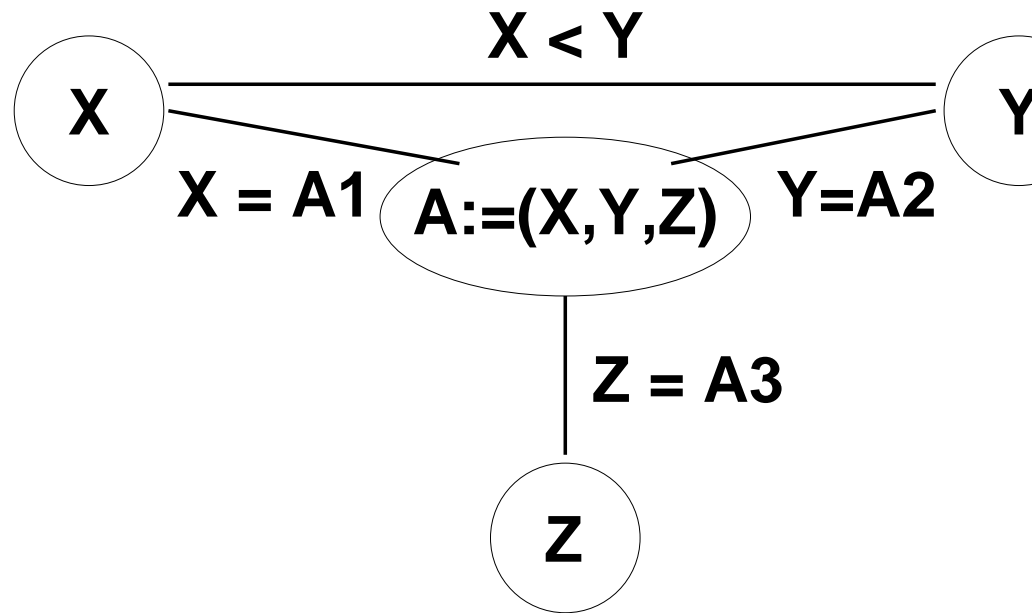

binarized constraint graph

Auxiliary Variables

Sometimes auxiliary variables also are necessary to represent a problem as CSP.

Example: cryptarithmic puzzle.

Assign each letter a figure

s.t. the resulting arithmetic expression is true.

$$\begin{array}{r}
 \text{T W O} \\
 + \text{T W O} \\
 \hline
 \text{F O U R}
 \end{array}$$

$$\begin{aligned}
 O + O &= R + 10X_1 \\
 X_1 + W + W &= U + 10X_2 \\
 X_2 + T + T &= O + 10X_3 \\
 X_3 &= F
 \end{aligned}$$

1. Constraint Satisfaction Problems

2. Backtracking Search

3. Local Search

4. The Structure of Problems

Depth-First Search: Backtracking

Uninformed Depth-First search is called **backtracking** for CSPs.

```

1 backtrack( variables  $\mathcal{X}$ , constraints  $\mathcal{C}$ , assignment  $A$  ) :
2 if  $\mathcal{X} = \emptyset$  return  $A$  fi
3  $X := \text{choose}(\mathcal{X})$ 
4  $A' := \text{failure}$ 
5 for  $v \in \text{values}(X, A, \mathcal{C})$  while  $A' = \text{failure}$  do
6    $A' := \text{backtracking}(\mathcal{X} \setminus \{X\}, \mathcal{C}, A \cup \{X = v\})$ 
7 od
8 return  $A'$ 

```

where

$$\text{values}(X, A, \mathcal{C}) := \{v \in \text{dom } X \mid \forall C \in \mathcal{C} \text{ with } \text{var } C \subseteq \text{var } A \cup \{X\} : C(A, X = v) = \text{true}\}$$

denotes the values for variable X consistent with assignment A for constraints \mathcal{C} .

Backtracking / Example



Backtracking / Example

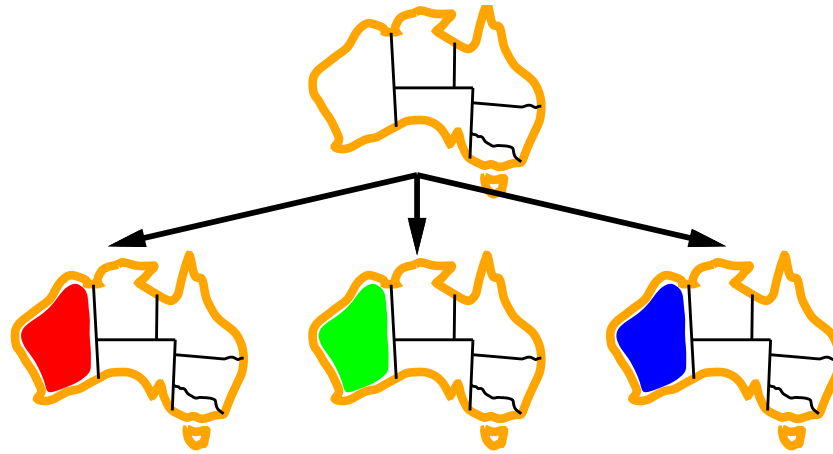

Backtracking / Example

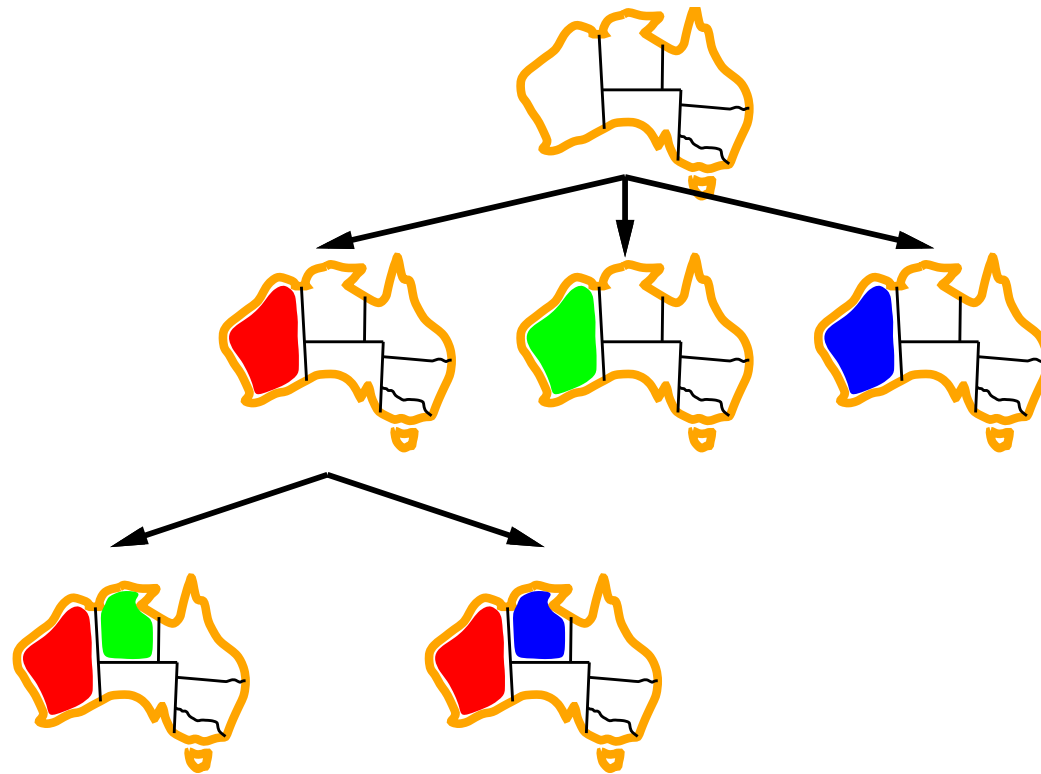

Backtracking / Example

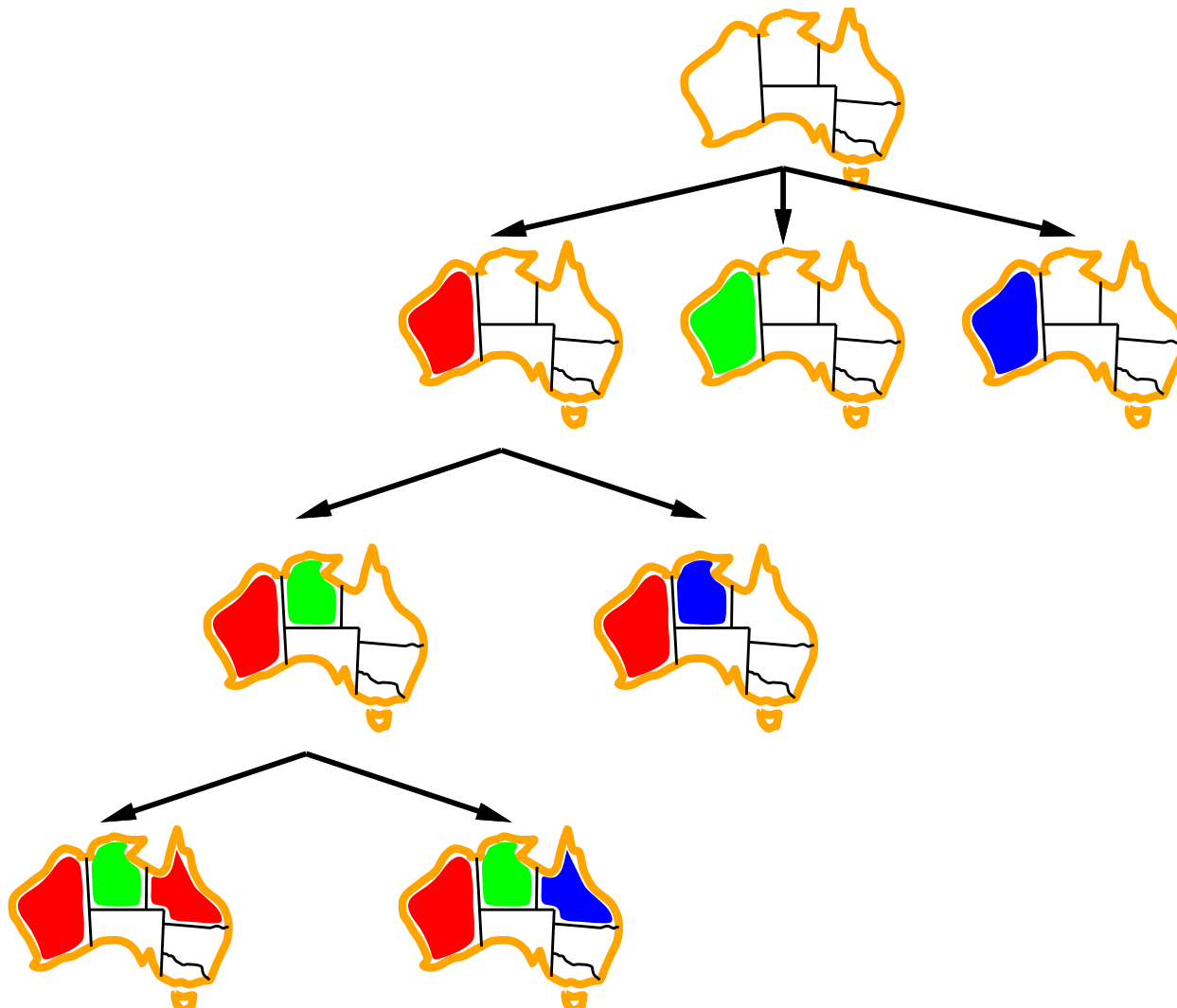

Variable Ordering / MRV

Which variable is selected in line 3 can be steered by heuristics:

minimum remaining values (MRV):

Select the variable with the smallest number of remaining choices:

$$X := \operatorname{argmin}_{X \in \mathcal{X}} |\operatorname{values}(X, A, \mathcal{C})|$$

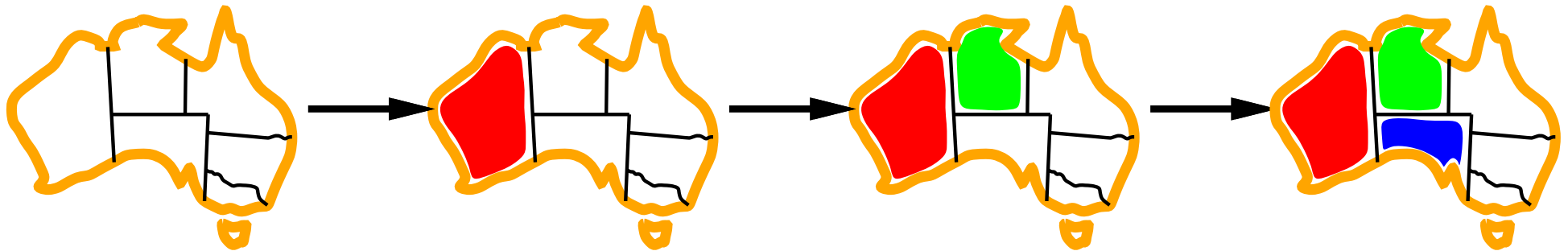

Variable Ordering / Degree Heuristics

degree heuristic:

Select the variable that is involved in the largest number of unresolved constraints:

$$X := \operatorname{argmax}_{X \in \mathcal{X}} |\{C \in \mathcal{C} \mid X \in \operatorname{var} C, \operatorname{var} C \not\subseteq \operatorname{var} A \cup \{X\}\}|$$

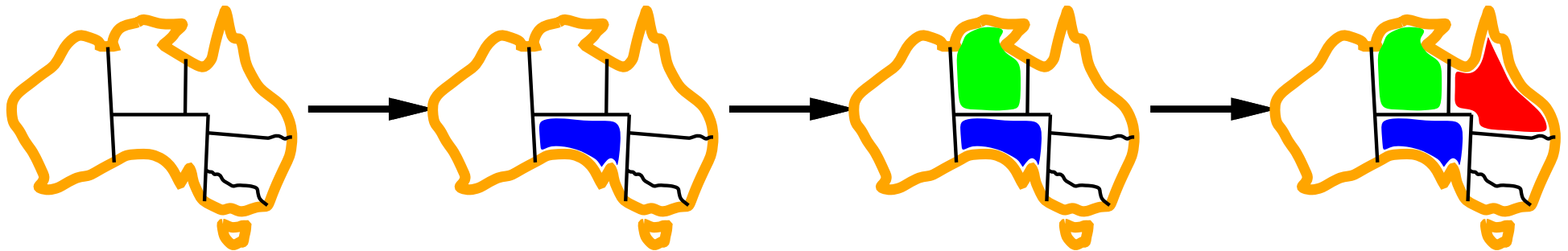

Usually one first applies MRV and breaks ties by degree heuristics.

Value Ordering

The order in which values for the selected variable are tried can also be steered by a heuristics:

least constraining value:

Order the values by descending number of choices for the remaining variables:

$$\sum_{Y \in \mathcal{X} \setminus \{X\}} |\text{values}(Y, A \cup \{X = v\}, \mathcal{C})|, \quad v \in \text{values}(X, A, \mathcal{C})$$

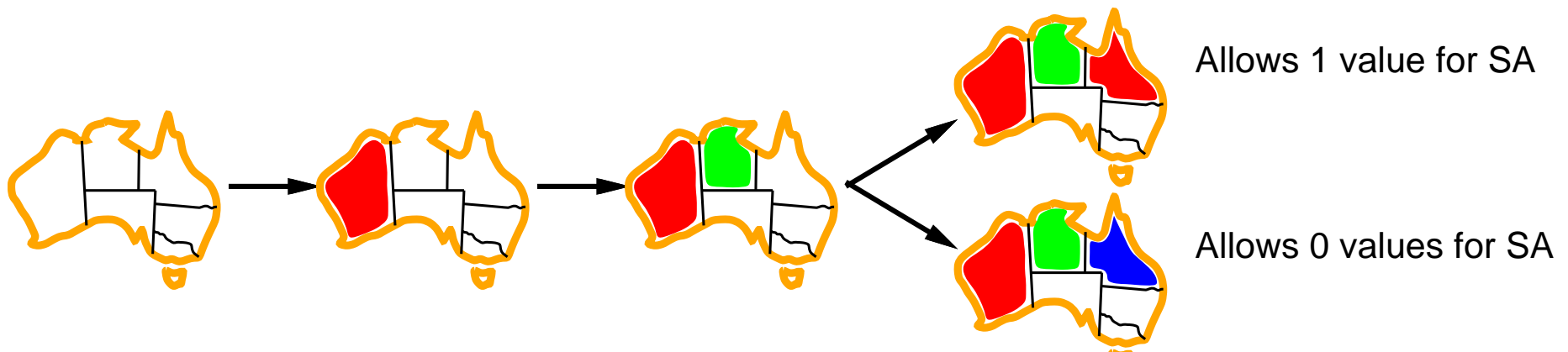

Forward Checking

The minimum remaining values (MRV) heuristics can be implemented efficiently by keeping track of the remaining values $\text{values}(X, A, \mathcal{C})$ of all unassigned variables.

— This is called **forward checking**.

```

1 backtracking-fc(variables  $\mathcal{X}$ ,  $(\text{values}(X))_{X \in \mathcal{X}}$ , constraints  $\mathcal{C}$ , assignment  $A$ ) :
2 if  $\mathcal{X} = \emptyset$  return  $A$  fi
3  $X := \text{argmin}_{X \in \mathcal{X}} |\text{values}(X)|$ 
4  $A' := \text{failure}$ 
5 for  $v \in \text{values}(X)$  while  $A' = \text{failure}$  do
6    $\text{illegal}(Y) := \{w \in \text{values}(Y) \mid \exists C \in \mathcal{C} : X, Y \in \text{var } C, \text{var } C \subseteq \text{var } A \cup \{X, Y\},$ 
7      $C(A, X = v, Y = w) = \text{false}\}, \quad \forall Y \in \mathcal{X} \setminus \{X\}$ 
8    $A' := \text{backtracking}(\mathcal{X} \setminus \{X\}, (\text{values}(Y) \setminus \text{illegal}(Y))_{Y \in \mathcal{X} \setminus \{X\}}, \mathcal{C}, A \cup \{X = v\})$ 
9 od
10 return  $A'$ 

```

Forward Checking

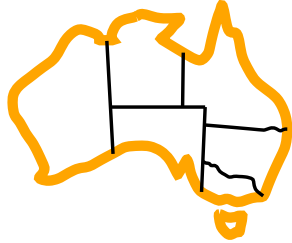

WA

NT

Q

NSW

V

SA

T



Forward Checking

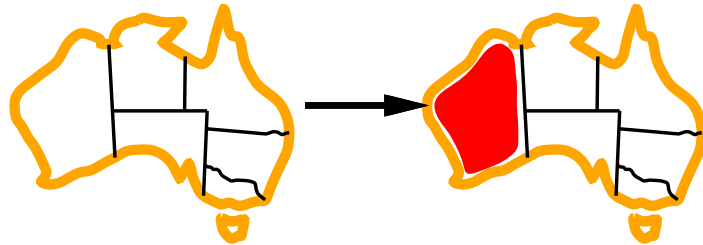

WA

NT

Q

NSW

V

SA

T

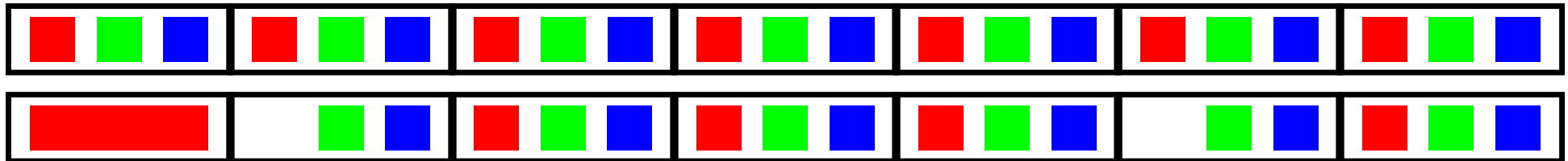

Forward Checking

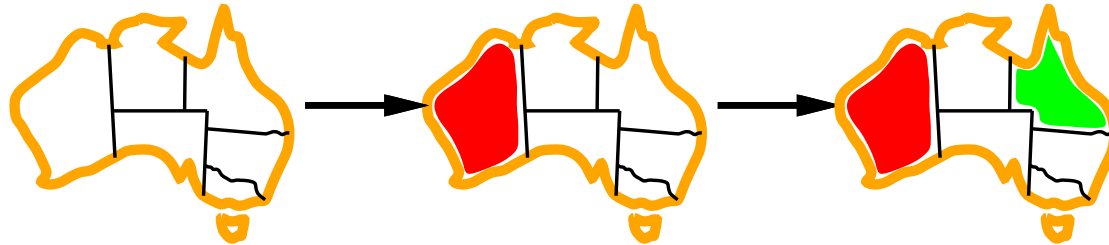

WA

NT



















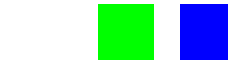
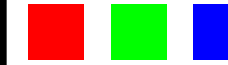

Q

NSW

V

SA

T

Forward Checking

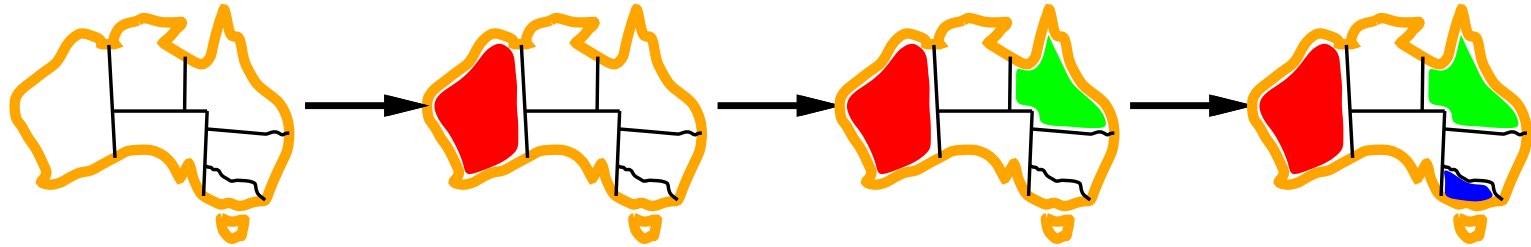

WA

NT

Q

NSW

V

SA

T

Arc Consistency

One also could use a stronger consistency check: if

- there is for some unassigned variable X a possible value v ,
- there is a constraint C linking X to another unassigned variable Y , and
- setting $X = v$ would rule out all remaining values for Y via C ,

then we can remove v as possible value for X .

Example:

$$\text{values}(\text{SA}) = \{b\}, \quad \text{values}(\text{NSW}) = \{r, b\}, \quad C : \text{NSW} \neq \text{SA}$$

$\text{NSW} = b$ is not possible as C would lead to $\text{values}(\text{SA}) = \emptyset$.

Removing such a value may lead to other inconsistent arcs, thus, has to be done repeatedly.

Arc Consistency

```
1 arc-consistency(variables  $\mathcal{X}$ ,  $(\text{values}(X))_{X \in \mathcal{X}}$ , constraints  $\mathcal{C}$ ) :  
2 arcs :=  $((X, Y, C) \in \mathcal{X}^2 \times \mathcal{C} \mid \text{var } C = \{X, Y\})$  in any order  
3 while arcs  $\neq \emptyset$  do  
4      $(X, Y, C) := \text{remove-first}(\text{arcs})$   
5     illegal :=  $\{v \in \text{values}(X) \mid \forall w \in \text{values}(Y) : C(X = v, Y = w) = \text{false}\}$   
6     if illegal  $\neq \emptyset$   
7         values( $X$ ) := values( $X$ )  $\setminus$  illegal  
8         append(arcs,  $((Y', X', C') \in \mathcal{X}^2 \times \mathcal{C} \mid X' = X, Y' \neq Y, \text{var } C' = \{X', Y'\})$ )  
9     fi  
10 od  
11 return  $(\text{values}(X))_{X \in \mathcal{X}}$ 
```

Arc Consistency

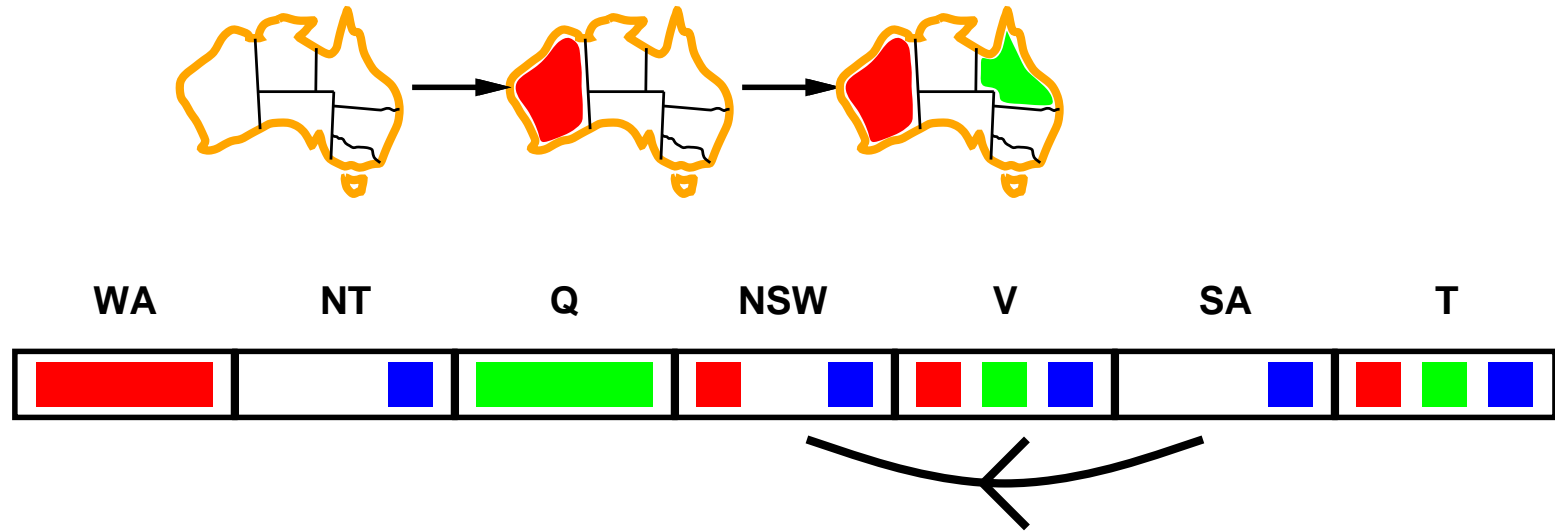

Arc Consistency

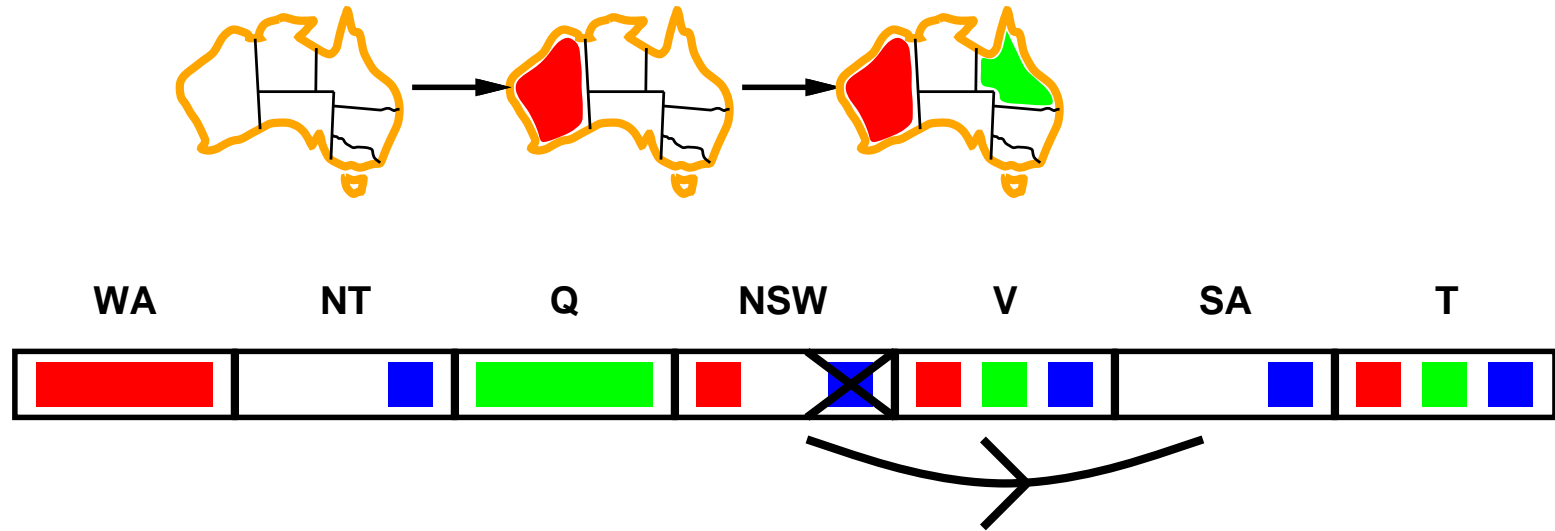

Arc Consistency

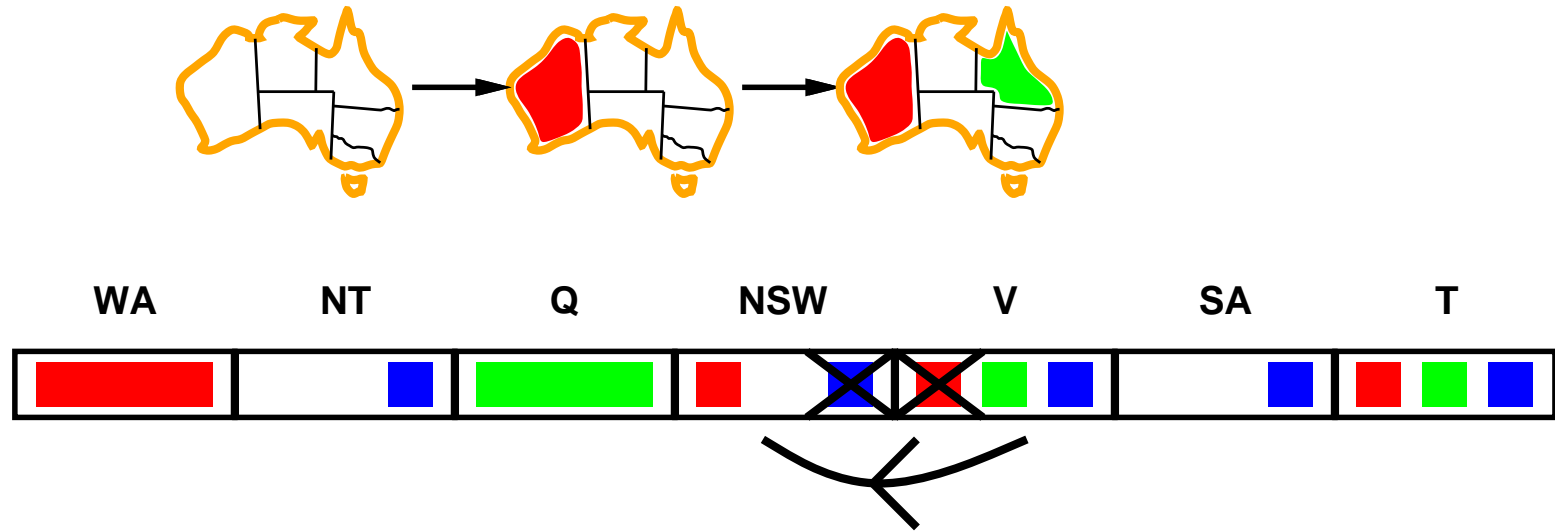

k -consistency

k -consistency:

any consistent assignment of any $k - 1$ variables can be extended to a consistent assignment of k variables with any k -th variable.

1-consistency: node consistency

same as forward checking.

2-consistency: arc consistency

3-consistency: path consistency

strong k -consistent: 1-consistent and 2-consistent and ... and k -consistent.

strong n -consistency (where n is the number of variables)

renders a CSP trivial:

select a value for X_1 , compute the remaining values for the other variables, then pick on for X_2 etc. — strong n -consistency guarantees that there is no step where backtracking is necessary.

1. Constraint Satisfaction Problems

2. Backtracking Search

3. Local Search

4. The Structure of Problems

min conflicts

sort of greedy local search:

states: complete assignments

neighborhood: re-assigning a (randomly picked) conflicting variable

goal: no conflicts

```

1 min-conflicts(variables  $\mathcal{X}$ , constraints  $\mathcal{C}$ ) :
2  $A :=$  random complete assignment for  $\mathcal{X}$ 
3 for  $i := 1 \dots \text{maxsteps}$  while  $\exists C \in \mathcal{C} : C(A) = \text{false}$  do
4    $X := \text{random}(\{X \in \mathcal{X} \mid \exists C \in \mathcal{C} : C(A) = \text{false} \text{ and } X \in \text{var } C\})$ 
5    $v := \text{argmin}_{v \in \text{dom } X} |\{C \in \mathcal{C} \mid C(A, X = v) = \text{false}, X \in \text{var } C\}|$ 
6    $A|_X := v$ 
7 od
8 return  $A$ , if  $\forall C \in \mathcal{C} : C(A) = \text{true}$ , failure else
  
```

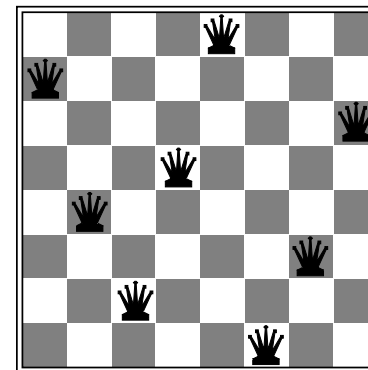
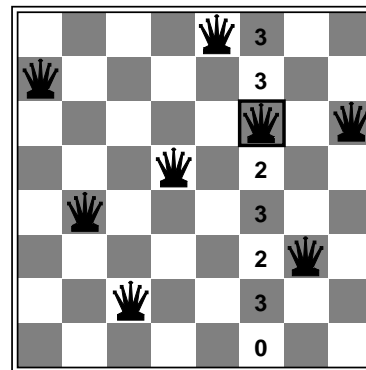
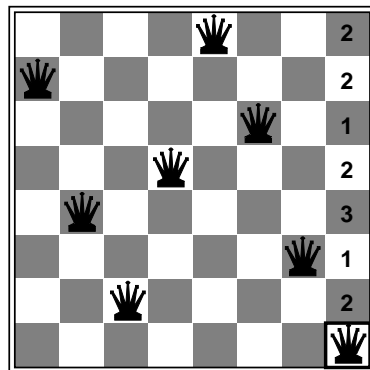

min conflicts / performance

min conflicts finds solution for n -queens problem very quickly even for very large n , e.g., $n = 10,000,000$ (starting from a random initial state).

min conflicts also can solve large randomly-generated CSPs very quickly

except in a narrow range of the constraints / variables ratio

$$R := \frac{\text{number of constraints}}{\text{number of variables}}$$

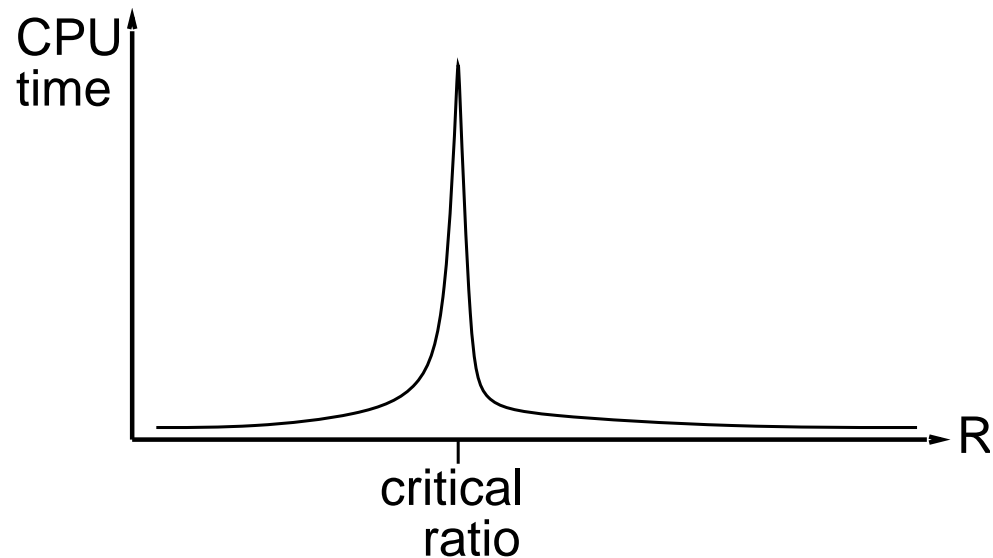

1. Constraint Satisfaction Problems

2. Backtracking Search

3. Local Search

4. The Structure of Problems

Connected Components / Graphs

Let $G := (V, E)$ be an undirected graph.

A sequence $p = (p_1, \dots, p_n) \in V^*$ of vertices is called **path** of G if

$$(p_i, p_{i+1}) \in E \quad \text{for } i = 1 \dots, n - 1$$

G^* denotes the set of paths on G .

$x, y \in V$ are called **connected** if there is a path in G between x and y ,

i.e., it exists $p \in G^*$ with $p_1 = x$ and $p_{|p|} = y$.

G is called **connected** if all pairs of vertices are connected.

A maximal connected subgraph $G' := (V', E')$ of G is called **connection component** of G .

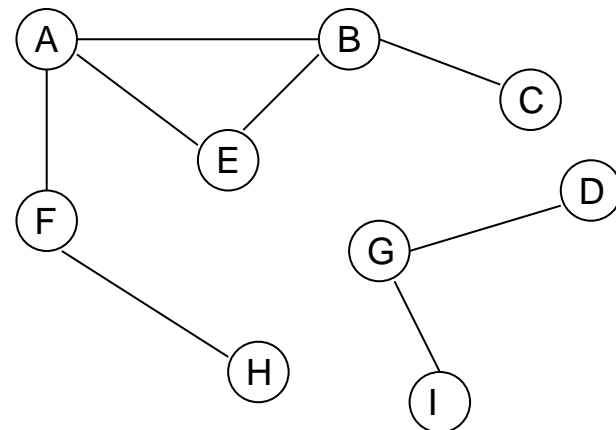

Connected Components / Graphs

Let $G := (V, E)$ be an undirected graph.

A sequence $p = (p_1, \dots, p_n) \in V^*$ of vertices is called **path** of G if

$$(p_i, p_{i+1}) \in E \quad \text{for } i = 1 \dots, n - 1$$

G^* denotes the set of paths on G .

$x, y \in V$ are called **connected** if there is a path in G between x and y ,

i.e., it exists $p \in G^*$ with $p_1 = x$ and $p_{|p|} = y$.

G is called **connected** if all pairs of vertices are connected.

A maximal connected subgraph $G' := (V', E')$ of G is called **connection component** of G .

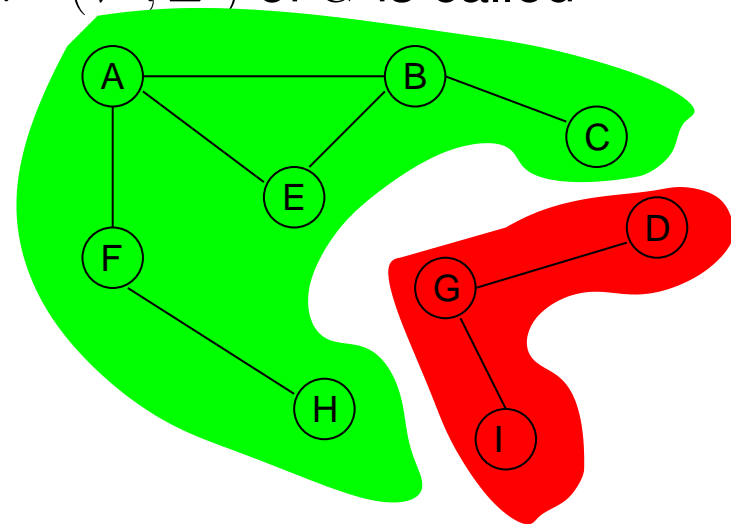

Connected Components / Hypergraphs

Let $G := (V, E)$ be a hypergraph, i.e., $E \subseteq \mathcal{P}(V)$.

A sequence $p = (p_1, \dots, p_n) \in E^*$ of edges is called **path** of G if

$$p_i \cap p_{i+1} \neq \emptyset \quad \text{for } i = 1 \dots, n - 1$$

G^* denotes the set of paths on G .

$x, y \in V$ are called **connected** if there is a path in G between x and y ,

i.e., it exists $p \in G^*$ with $x \in p_1$ and $y \in p_{|p|}$.

G is called **connected** if all pairs of vertices are connected.

A maximal connected subgraph $G' := (V', E')$ of G is called **connection component** of G .

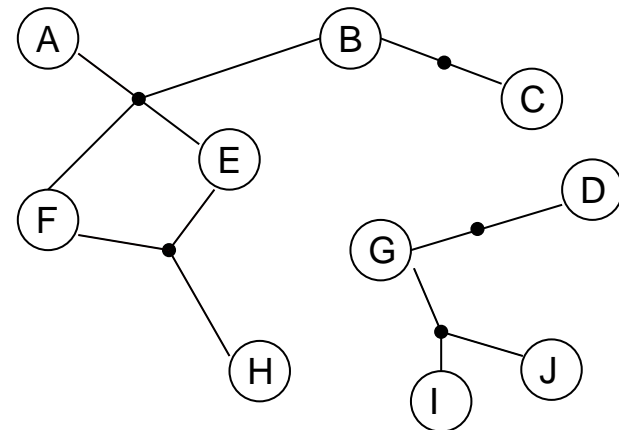

Connected Components / Hypergraphs

Let $G := (V, E)$ be a hypergraph, i.e., $E \subseteq \mathcal{P}(V)$.

A sequence $p = (p_1, \dots, p_n) \in E^*$ of edges is called **path** of G if

$$p_i \cap p_{i+1} \neq \emptyset \quad \text{for } i = 1 \dots, n - 1$$

G^* denotes the set of paths on G .

$x, y \in V$ are called **connected** if there is a path in G between x and y ,

i.e., it exists $p \in G^*$ with $x \in p_1$ and $y \in p_{|p|}$.

G is called **connected** if all pairs of vertices are connected.

A maximal connected subgraph $G' := (V', E')$ of G is called **connection component** of G .

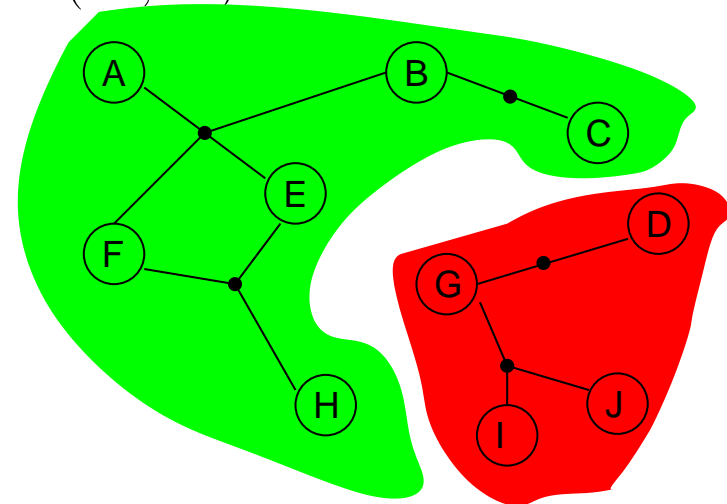

Independent Subproblems

Let $(\mathcal{X}, \mathcal{C})$ be a constraint satisfaction problem.
The CSP $(\mathcal{X}', \mathcal{C}')$ with $\mathcal{X}' \subseteq \mathcal{X}$ and

$$\mathcal{C}' := \{C \in \mathcal{C} \mid \text{var } C \subseteq \mathcal{X}'\}$$

is called **subproblem of $(\mathcal{X}, \mathcal{C})$ on the variables \mathcal{X}'** .

Two subproblems on the variables \mathcal{X}'_1 and \mathcal{X}'_2 are called **independent** if there is no joining constraint, i.e., no $C \in \mathcal{C}$ with

$$\text{var } C \cap \mathcal{X}'_1 \neq \emptyset \text{ and } \text{var } C \cap \mathcal{X}'_2 \neq \emptyset$$

(and thus $\mathcal{X}'_1 \cap \mathcal{X}'_2 = \emptyset$).

I.e., if the respective constraint sub-hypergraphs are unconnected.

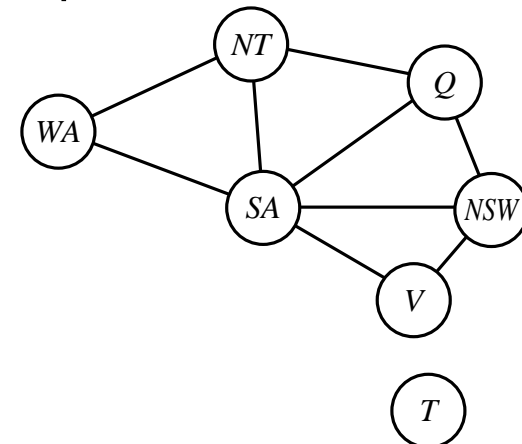

Independent Subproblems

Consistent assignments of independent subproblems can be joined to consistent assignments of the whole problem.

The other way around:

if a problem decomposes into independent subproblems
we can solve each one separately
and joint the subproblem solutions afterwards.

Tree Constraint Graphs

The next simple case:

If the constraint graph is a tree,

there is a linear-time algorithm to solve the CSP:

1. choose any vertex as the root of the tree,
2. order the variables from root to leaves
s.t. parents precede their children in the ordering.
(topological ordering)
Denote variables by $X_{(1)}, X_{(2)}, \dots, X_{(n)}$.
3. For $i = n$ down to 2:
apply arc consistency to the edge $(\text{parent}(X_{(i)}), X_{(i)})$
i.e., eventually remove values from $\text{dom } \text{parent}(X_{(i)})$.
4. For $i = 1$ to n :
choose a value for $X_{(i)}$ consistent with the value already
chosen for $\text{parent}(X_{(i)})$.

Tree Constraint Graphs

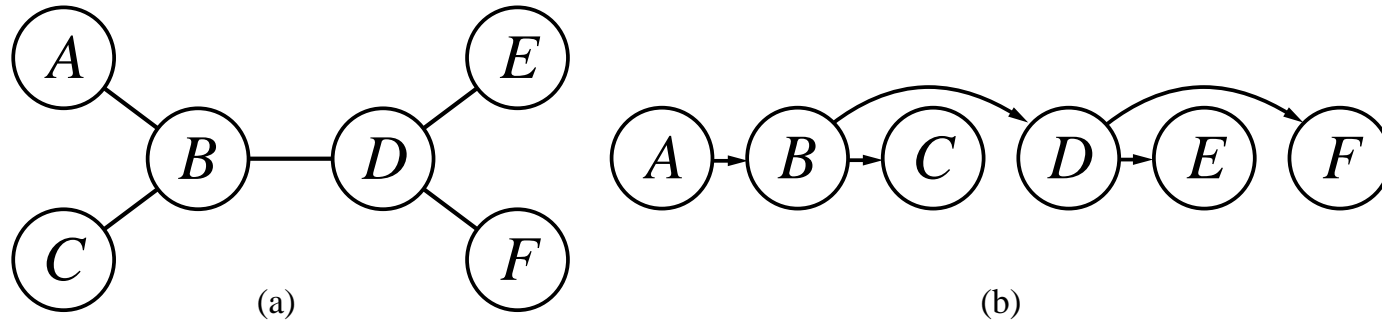

General Constraint Graphs

Idea: try to reduce problem to constraint trees.

Approach 1: **cycle cutset**

remove some vertices s.t. the remaining vertices form a tree.

for binary CSPs:

1. find a subset $S \subseteq \mathcal{X}'$ of variables
s.t. the constraint graph of the subproblem on $\mathcal{X} \setminus S$ becomes a tree.
2. for each consistent assignment A on S :
 - (a) remove from the domains of $\mathcal{X} \setminus S$ all values not consistent with A ,
 - (b) search for a solution of the remaining CSP.
if there is one, an overall solution has been found.

General Constraint Graphs / Cycle cutset

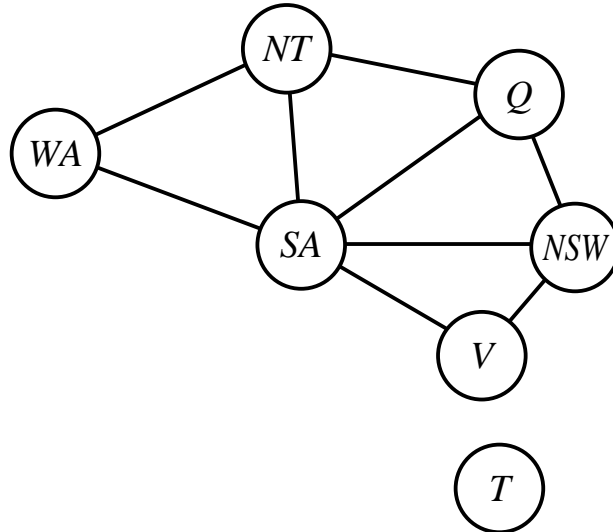

General Constraint Graphs / Cycle cutset

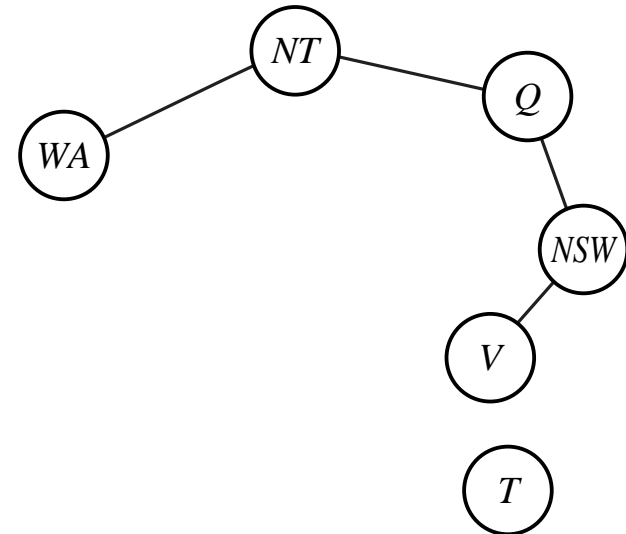
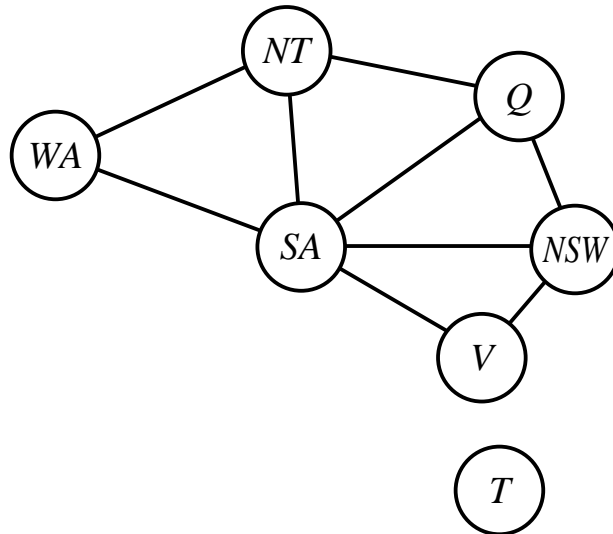

The smaller the cutset, the better.

Finding the smallest cutset is NP-hard.

General Constraint Graphs / Tree Decompositions

Approach 2: **tree decomposition**

decompose the constraint graph in overlapping subgraphs

s.t. the overlapping structure forms a tree

Tree decomposition $(\mathcal{X}_i)_{i=1,\dots,m}$:

1. each vertex appears in at least one subgraph.
2. each edge appears in at least one subgraph.
3. if a vertex appears in two subgraphs, it must appear in every subgraph along the path connecting those two vertices.

General Constraint Graphs / Tree Decompositions

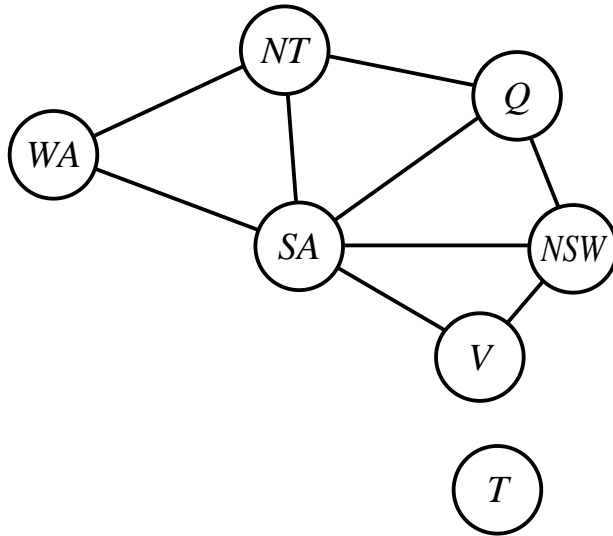

General Constraint Graphs / Tree Decompositions

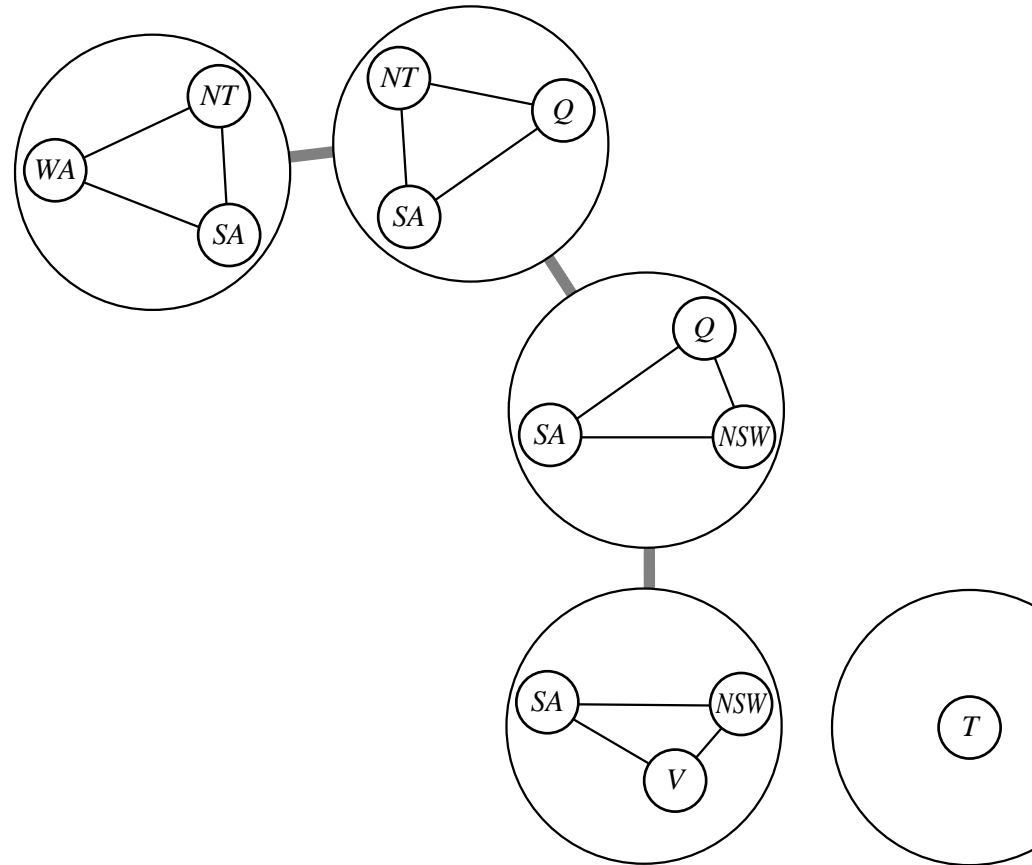
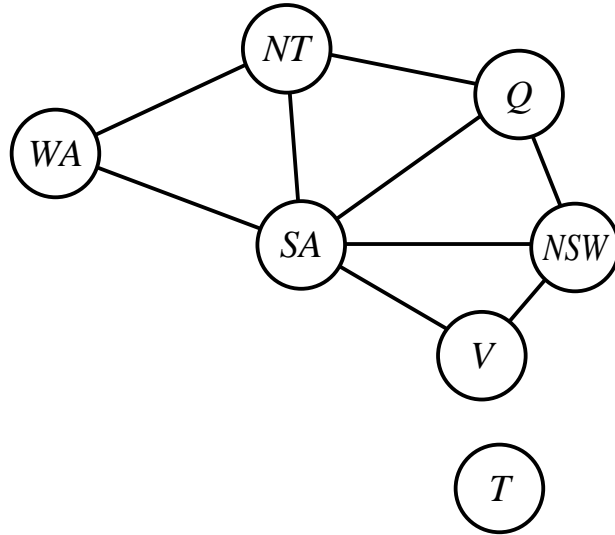

General Constraint Graphs / Tree Decompositions

To solve the CSP:
view each subgraph as a new variable
and apply the algorithm for trees sketched earlier.

Example:

$$(WA, SA, NT) = (r, b, g) \Rightarrow (SA, NT, Q) = (b, g, r)$$

In general, many tree decompositions possible.

The **treewidth** of a tree decomposition is the size of the largest subgraph minus 1.

The smaller the treewidth, the better.

Finding the tree decomposition with minimal treewidth is NP-hard.

Summary

- CSPs allow to describe problems by **variables** and **constraints** between them.
- Depth-first search assigning one variable a time (called **backtracking**) can be used to solve CSPs.
- Heuristics for choosing the next variable to assign (**MRV**; **degree heuristics**) and for ordering the values (**least constraining value**) can accelerate backtracking.
- MRV can be efficiently implemented keeping book of the remaining values for each unassigned variable (**forward checking**).
- More complex methods of constraint propagation (such as **arc consistency**) can be used to lower the risk of having to backtrack.
- Local search (**min conflicts**) can be used to solve CSPs quickly.
- **Tree-structured CSPs** can be solved in linear time.